

Requested Patent: WO03045294A1
Title: ABSORBENT WOUND DRESSINGS CONTAINING A HYDROGEL LAYER ;
Abstracted Patent: GB2382305 ;
Publication Date: 2003-05-28 ;
Inventor(s): KIRKWOOD ANDREW JAMES (GB); SILCOCK DEREK (GB) ;
Applicant(s): JOHNSON JOHNSON MEDICAL LTD (GB) ;
Application Number: GB20010028152 20011123 ;
Priority Number(s): GB20010028152 20011123 ;
IPC Classification: A61F13/00; A61L15/16 ;
Equivalents: ;

ABSTRACT:

The invention provides a wound dressing comprising: a liquid-permeable top sheet having a wound facing surface and a back surface, said top sheet being adapted to block or restrict passage of liquid from the back surface to the wound facing surface; and a hydrogel layer adjacent to the back surface of the top sheet.

(19) World Intellectual Property Organization
International Bureau



(43) International Publication Date
5 June 2003 (05.06.2003)

PCT

(10) International Publication Number
WO 03/045294 A1

- (51) International Patent Classification⁷: A61F 13/02
- (21) International Application Number: PCT/GB02/05253
- (22) International Filing Date:
22 November 2002 (22.11.2002)
- (25) Filing Language: English
- (26) Publication Language: English
- (30) Priority Data:
0128152.6 23 November 2001 (23.11.2001) GB
- (71) Applicant (for all designated States except US): JOHNSON & JOHNSON MEDICAL LIMITED [GB/GB]; Erskine House, 68-73 Queen Street, Edinburgh EH2 4NH (GB).
- (72) Inventors; and
- (75) Inventors/Applicants (for US only): SILCOCK, Derek [GB/GB]; 2 Ash Grove, Skipton, North Yorkshire BD23 1QP (GB). KIRKWOOD, Andrew, James [GB/GB]; 19 Stephenson Walk, Cottingham, Hull HU16 4QD (GB).
- (74) Agents: JAMES, Anthony, Christopher W., P. et al.; Carpmaels & Ransford, 43 Bloomsbury Square, London WC1A 2RA (GB).
- (81) Designated States (national): AE, AG, AL, AM, AT, AU, AZ, BA, BB, BG, BR, BY, BZ, CA, CH, CN, CO, CR, CU, CZ, DE, DK, DM, DZ, EC, EE, ES, FI, GB, GD, GE, GH, GM, HR, HU, ID, IL, IN, IS, JP, KE, KG, KP, KR, KZ, LC, LK, LR, LS, LT, LU, LV, MA, MD, MG, MK, MN, MW, MX, MZ, NO, NZ, OM, PH, PL, PT, RO, RU, SC, SD, SE, SG, SI, SK, SL, TJ, TM, TN, TR, TT, TZ, UA, UG, US, UZ, VC, VN, YU, ZA, ZM, ZW.

[Continued on next page]

(54) Title: ABSORBENT WOUND DRESSING CONTAINING A HYDROGEL LAYER

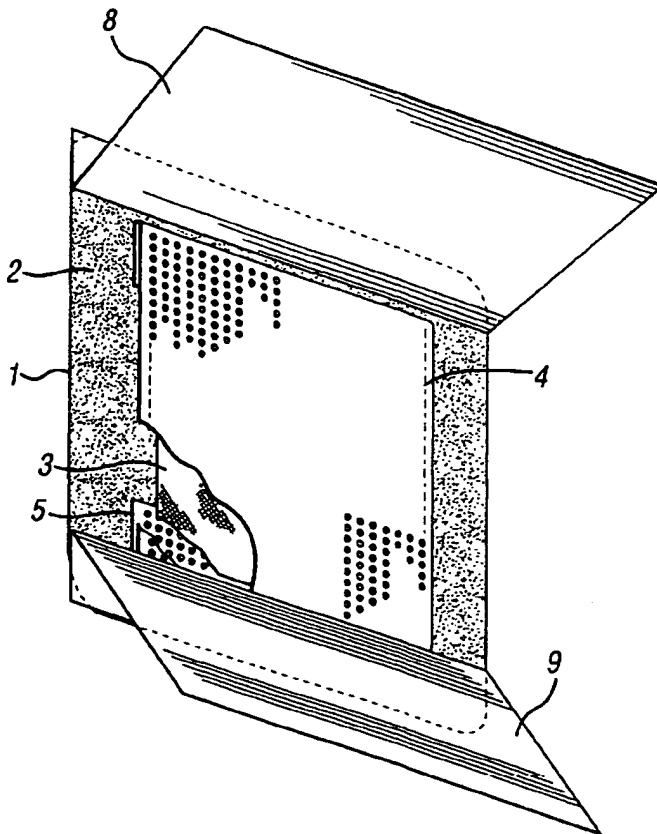

(57) Abstract: The invention provides a wound dressing comprising : a liquid-permeable top sheet having a wound facing surface and a back surface, said top sheet being adapted to block or restrict passage of liquid from the back surface to the wound facing surface ; and an insoluble hydrogel layer adjacent to the back surface of the top sheet.



WO 03/045294 A1



(84) **Designated States** (*regional*): ARIPO patent (GH, GM, KE, LS, MW, MZ, SD, SL, SZ, TZ, UG, ZM, ZW), Eurasian patent (AM, AZ, BY, KG, KZ, MD, RU, TJ, TM), European patent (AT, BE, BG, CH, CY, CZ, DE, DK, EE, ES, FI, FR, GB, GR, IE, IT, LU, MC, NL, PT, SE, SK, TR), OAPI patent (BF, BJ, CF, CG, CI, CM, GA, GN, GQ, GW, ML, MR, NE, SN, TD, TG).

Published:

— *with international search report*

For two-letter codes and other abbreviations, refer to the "Guidance Notes on Codes and Abbreviations" appearing at the beginning of each regular issue of the PCT Gazette.

ABSORBENT WOUND DRESSINGS CONTAINING A HYDROGEL LAYER

The present invention relates to wound dressings incorporating an absorbent structure and a hydrogel layer for the maintenance of a suitable
5 moisture level at the surface of wounds.

It is known that the maintenance of a moist wound environment promotes the healing of wounds, especially burns and chronic wounds such as ulcers. However, it is also desirable to avoid excessive moisture or pooling of wound
10 exudate on the wound, since liquid exudate causes maceration of skin adjacent to the wound and other difficulties. Furthermore, liquid exudate can leak from the wound site and contaminate clothes or bedding.

In practice, it is difficult to maintain the desired moisture level at the wound
15 site because the rate of wound fluid production varies from wound to wound, and over time for any single wound. This can necessitate frequent dressing changes and a range of dressing types to treat different wounds.

It is an object of the present invention to provide structures for use as or in
20 improved multilayer dressings for the treatment of a wide range of wounds.

The present invention provides a wound dressing comprising: a liquid-permeable top sheet having a wound facing surface and a back surface, said top sheet being adapted to block or restrict passage of liquid from the back surface to
25 the wound facing surface; and a hydrogel layer adjacent to the back surface of the top sheet.

Preferably, the dressing further comprises a backing layer over the back face of the top sheet. The backing layer supports the top sheet and an
30 intermediate absorbent layer (where present) and preferably provides a barrier to passage of microorganisms through the dressing. The backing layer may extend beyond at least one edge of the absorbent layer to provide an adhesive-coated margin adjacent to the said edge for adhering the dressing to a surface, such as to

the skin of a patient adjacent to the wound being treated. An adhesive-coated margin may extend around all sides of the absorbent layer, so that the dressing is a so-called island dressing. However, it is not necessary for there to be any adhesive-coated margin.

5

Preferably, the backing layer is substantially liquid-impermeable. The backing sheet is preferably semipermeable. That is to say, the backing sheet is preferably permeable to water vapour, but not permeable to liquid water or wound exudate. Preferably, the backing sheet is also microorganism-impermeable.

10 Suitable continuous conformable backing sheets will preferably have a moisture vapor transmission rate (MVTR) of the backing sheet alone of 300 to 5000 g/m²/24hrs, preferably 500 to 2000 g/m²/24hrs at 37.5 C at 100% to 10% relative humidity difference. The backing sheet thickness is preferably in the range of 10 to 1000 micrometers, more preferably 100 to 500 micrometers.

15

The MVTR of the dressing according to the present invention as a whole is lower than that of the backing sheet alone, because the top sheet partially obstructs moisture transfer through the dressing. Preferably, the MVTR of the dressing (measured across the island portion of the dressing) is from 20% to 80%

20 of the MVTR of the backing sheet alone, more preferably from 20% to 60% thereof, and most preferably about 40% thereof. It has been found that such moisture vapor transmission rates allow the wound under the dressing to heal under moist conditions without causing the skin surrounding the wound to macerate.

25

Suitable polymers for forming the backing sheet include polyurethanes and poly alkoxyalkyl acrylates and methacrylates such as those disclosed in GB-A-1280631. Preferably, the backing sheet comprises a continuous layer of a high density blocked polyurethane foam that is predominantly closed-cell. A suitable

30 backing sheet material is the polyurethane film available under the Registered Trade Mark ESTANE 5714F.

The adhesive (where present) layer should be moisture vapor transmitting and/or patterned to allow passage of water vapor therethrough. The adhesive layer is preferably a continuous moisture vapor transmitting, pressure-sensitive adhesive layer of the type conventionally used for island-type wound dressings, for example, a pressure sensitive adhesive based on acrylate ester copolymers, polyvinyl ethyl ether and polyurethane as described for example in GB-A-1280631. The basis weight of the adhesive layer is preferably 20 to 250 g/m², and more preferably 50 to 150 g/m². Polyurethane-based pressure sensitive adhesives are preferred.

10

Preferably, the adhesive layer extends outwardly from the absorbent layer and the top sheet to form an adhesive-coated margin on the backing sheet around the adhesive layer as in a conventional island dressing.

15 The area of the optional absorbent layer is typically in the range of from 1cm² to 200cm², more preferably from 4cm² to 100cm².

The optional absorbent layer may be any of the layers conventionally used for absorbing wound fluids, serum or blood in the wound healing art, including foams, sponges, gauzes, and nonwoven fabrics, and combinations thereof. Superabsorbents or hydrogels may be dispersed in the optional absorbent layer to improve liquid absorbency and retention. Preferably, the absorbent layer comprises a layer of absorbent foam, such as an open celled hydrophilic polyurethane foam prepared in accordance with EP-A-0541391, the entire content of which is expressly incorporated herein by reference. In other embodiments, the absorbent layer may be a nonwoven fibrous web, for example a carded web of viscose staple fibers. The basis weight of the absorbent layer may be in the range of 50-500g/m², such as 100-400g/m². The uncompressed thickness of the absorbent layer may be in the range of from 0.5mm to 10mm, such as 1mm to 4mm. The free (uncompressed) liquid absorbency measured for physiological saline may be in the range of 5 to 30 g/g at 25°C.

The optional absorbent layer is a separate layer from the hydrogel layer in the wound dressings according to the present invention, and is located on the opposite side of the hydrogel layer from the top sheet. In certain embodiments the hydrogel layer and the optional absorbent layer are adjacent, and in certain
5 embodiments they are laminated together.

The optional absorbent layer may additionally comprise one or more active therapeutic or antimicrobial agents. Suitable therapeutic agents include growth factors, analgesics, local anaesthetics and steroids. Suitable antimicrobial agents
10 include antiseptics such as silver compounds (e.g. silver sulfadiazine) and chlorhexidine, and antibiotics. The therapeutic or antimicrobial agents are usually added in an amount of from 0.01% to 5% by weight, based on the dry weight of the absorbent layer. Provision of the antimicrobial in the absorbent layer may be
15 preferable for two reasons (1) Simple manufacturing route, and (2) Having the antimicrobial away from the wound would prevent unnecessary exposure to the antimicrobial when it may not be needed, e.g. drier wounds. In the presence of higher exudate, higher levels of the antimicrobial will be released as the absorbent layer becomes wet. Whilst the directional top sheet should restrict the flow of exudate back to the wound (to some extent through surface tension of the liquid),
20 the antimicrobial should go against the concentration gradient and pass back through the perforated sheet and into the wound. It is known that antimicrobial components such as silver ions can be transported through relatively low levels of moisture.

25 The top sheet of the wound dressing according to the invention is liquid permeable, but acts to block or restrict the flow of liquid from the back surface to the wound site. That is to say, the top sheet allows fluid to pass through the top sheet from the wound site, but blocks or restricts flow of the fluid back through the top sheet onto the wound (also known as wet-back). Such non-wetting top sheets
30 may for example be made from porous non-woven fabrics comprising a layer of hydrophobic fibers, or having a hydrophobic finish applied to at least the outer surface thereof. Preferably, the top sheet has greater liquid permeability to the

flow of liquid away from the wound facing surface than to the flow of liquid towards the wound facing surface.

The top sheet film may be formed from a thermoplastic film-forming
5 polymer. Preferably, the polymer is conformable but not substantially elastomeric. Suitable polymers include, but are not limited to, polyethylene, polypropylene, polyester, polyamides such as nylons, fluoropolymers such as polyvinylidene fluoride (PVDF) or polytetrafluoroethylene (PTFE), and mixtures thereof. The top sheet is preferably a polyolefin film. Preferably, the film has a thickness by weight
10 (ASTM E252-84) of from 10 to 200 micrometers, more preferably from 25 to 100 micrometers.

It is an advantage of the present invention that the top sheet on its wound facing surface may be made hydrophobic so as to reduce adherency of the top
15 sheet to the wound. In alternative embodiments, a medically acceptable adhesive, for example of the kind described above, may be applied to the wound facing surface of the top sheet.

Preferably, the top sheet is formed from a substantially liquid-impermeable
20 sheet material provided with tapered capillaries, each capillary having a base substantially in the plane of the wound facing surface of the top sheet and an apical opening remote from the wound facing surface of the top sheet and preferably in contact with the hydrogel and/or the absorbent layer. The conical capillaries provide rapid one-way wicking of fluid from the front of the top sheet,
25 with minimal wet-back. Top sheets of this type are described in GB-A-1526778.

Preferably, the capillaries are substantially in the form of truncated cones. Preferably, the capillaries have a base opening dimension (the maximum opening dimension in the plane of the top sheet) of from 0.1 mm to 3 mm, and an apical
30 opening dimension (remote from the plane of the top sheet) of from 0.05 to 2 mm. More preferably, the capillaries have a base opening dimension as herein defined of from 0.3 mm to 1 mm, and an apical opening dimension of from 0.1 to 0.5 mm.

Preferably, the capillaries have an average angle of taper (measured from the perpendicular to the plane of the top sheet) of from 10 to 60 degrees. Preferably, the embossed thickness of the top sheet (by ASTM D374-79) is from 0.2 to 2 mm, more preferably from 0.4 to 1 mm.

5

Top sheets of this type may be manufactured, for example, by embossing or vacuum perforation of a liquid-impermeable thermoplastic film. Preferably, the density of the capillaries is from 10 to 400 per cm², more preferably from 50 to 200 per cm². Preferably, the open area of the top sheet is from 5 to 50% of the total
10 area, more preferably from 10 to 25% of the total area.

It has now been found, surprisingly, that the provision of a hydrogel layer adjacent to the back surface of such a top sheet enables a moist wound environment to be maintained for prolonged periods, over a wide range of wound
15 exudation rates. In preferred embodiments, the hydrogel layer is intermediate the top sheet and the optional absorbent layer, and preferably it contacts the back surface of the top sheet, and may be coated or bonded thereto. In use, the top sheet continues to wick away wound fluid to prevent excessive moisture in the wound. When the rate of wound exudate production falls, the hydrogel absorbs
20 moisture vapor from the absorbent layer and preserves a moist wound surface. The hydrogel does not give rise to substantially increased wet-back through the top sheet. Loss of hydrogel through the apertures of the top sheet is minimal, and the hydrogel does not interfere with the absorbent layer.

25 The top sheet provides a physical separation between the hydrogel layer and the wound surface, while enabling the humectant and moisture storage properties of the hydrogel to maintain a desired moisture level at the wound surface.

30 The term "hydrogel layer" refers to thin, two-dimensional layer, preferably consisting essentially of the hydrogel composition. Preferably it is substantially unitary layer, and preferably it has substantially constant thickness. The layer may be patterned or apertured. Preferably, the hydrogel layer is coextensive with the

top sheet. The term "hydrogel layer" does not refer to conventional fibrous absorbent pads having particles of hydrogels, in particular superabsorbents, dispersed therein. The advantages of the invention can be achieved with a thin hydrogel layer, which minimises the cost of the dressing. Preferably, the hydrogel layer has a dry basis weight of from 1 to 2000g/m², preferably from 5 to 1000 g/m², more preferably from 10 to 500g/m², still more preferably from 10 to 200g/m², still more preferably from 10 to 100g/m², and most preferably from 10 to 50g/m².

The term "hydrogel" refers generally to materials that interact with the wound fluid under physiological conditions to maintain an elevated moisture level at the wound surface. Preferably, the hydrogel layer forms a gel with water under physiological conditions of temperature and pH. Such hydrogel layers can be formed by the inclusion of medically acceptable macromolecular materials that preferably have the ability to swell and absorb fluid while maintaining a strong integral structure. The hydrogel material is substantially insoluble in water under physiological conditions, whereby the hydrogel is not washed away by the wound fluid. The hydrogel may be a biopolymer, and/or it may be bioabsorbable. That is to say, it may undergo gradual resorption *in vivo*.

Exemplary insoluble gels include certain cross-linked polyacrylate gels, calcium alginate gels, cross-linked hyaluronate gels, wherein the hydrogel layer comprises a hydrogel material selected from gels formed from vinyl alcohols, vinyl esters, vinyl ethers and carboxy vinyl monomers, meth(acrylic) acid, acrylamide, N-vinyl pyrrolidone, acylamidopropane sulphonic acid, PLURONIC (Registered Trade Mark) (block polyethylene glycol, block polypropylene glycol) polystyrene-, maleic acid, NN-dimethylacrylamide diacetone acrylamide, acryloyl morpholine, and mixtures thereof. Preferably, the gel adheres strongly to the surface of the top sheet material or of the optional absorbent layer or the backing sheet to resist washing off by wound fluid. In certain embodiments the gel may be directly coated or chemically bonded to the back surface of the top sheet.

Preferably, the hydrogel layer comprises a hydrogel material selected from polyurethane gels, biopolymer gels, carboxymethyl cellulose gels, hydroxyethyl

cellulose gels, hydroxy propyl methyl cellulose, modified acrylamide and mixtures thereof. Suitable biopolymer gels include alginates, pectins, galactomannans, chitosan, gelatin, hyaluronates and mixtures thereof. Some of these biopolymer materials also promote wound healing.

5

Preferably, the gels are cross-linked, and the cross-linking may be either covalent or ionic.

Preferably, the hydrogel material further comprises from 5 to 50% by weight
10 on a dry weight basis of one or more humectants such as glycerol.

Preferably, the hydrogel layer comprises a hydrogel material of the kind described in WO00/07638, the entire contents of which is incorporated herein by reference.

15

Alternatively or additionally to the gel-forming macromolecules, the hydrogel layer may comprise one or more emollients. Emollients are used to smooth the surface of skin and to increase the degree of hydration. They act either by occluding water loss from the outer layer of the skin, or by improving water binding
20 to the skin. Emollients are particularly useful in the treatment of atopic eczemas and ichthyoses. Preferred emollients include White Soft Paraffin, Yellow Soft Paraffin, Liquid paraffin, Urea Creams, Lanolin, Sodium Pyrrolidone Carboxylate (PCA Na), Evening primrose extract (gamma linolenic acid), Soya Oil, Tea Tree Oil, Coconut Oil, Almond Oil, Camomile Extract, Cod Liver Oil, Peanut Oil, Emu
25 Oil, Aloe Vera, Sunflower oil, Avocado Oil, Jojoba Oil, Cocoamide, and mixtures thereof.

The hydrogel layer may additionally comprise one or more active therapeutic or antimicrobial agents. Suitable therapeutic agents include growth
30 factors, analgesics, local anaesthetics and steroids. Suitable antimicrobial agents include antiseptics such as silver compounds (e.g. silver sulfadiazine) and chlorhexidine, and antibiotics. The therapeutic or antimicrobial agents are usually

added in an amount of from 0.01% to 5% by weight, based on the dry weight of the hydrogel layer.

The hydrogel layer may be continuous or discontinuous. Continuous
5 hydrogel layers extend over and cover the apertures in the back of the top sheet. Such continuous layers provide the advantage of temporarily blocking (gel blocking) the passage of wound fluid into the absorbent layer and/or through the backing sheet until the hydrogel is saturated. This helps to prevent drying out of wounds having low rates of exudate production.

10

In other embodiments the hydrogel layer is apertured. In some preferred
embodiments it is apertured in register with the capillaries in the top sheet so as
not to obstruct passage of fluid through the capillaries even when the hydrogel is
fully swelled. In other words, there is preferably substantially no hydrogel initially
15 present in or covering the capillaries of the top sheet. The hydrogel layer may be
applied by spraying or, preferably, by a printing or transfer process. The apertures
may be formed in the hydrogel layer for example by drilling with a hollow needle,
as described in US-A-XXXXXX, the entire content of which is hereby incorporated
by reference. In other embodiments, the apertures may be formed by casting the
20 top sheet in a mold having an array of projections corresponding to the apertures,
followed by peeling the hydrogel layer from the mold and applying it in register to
the top sheet.

Preferably, the multilayer wound dressing according to the invention further
25 comprises one or more protective cover sheets over the top sheet and any
exposed adhesive. For example, these may comprise one or more release-coated
paper cover sheets. Preferably, the dressing is sterile and packaged in a
microorganism-impermeable container.

30 The present invention further provides the use of a multilayer wound
dressing according to the present invention for the preparation of a dressing for
application to a wound.

In a further aspect, the present invention provides a method of treatment of a wound comprising the step of applying a dressing in accordance with the present invention to the surface of the wound with the top sheet contacting the wound.

5 An embodiment of the present invention will now be described further, by way of example, with reference to the accompanying drawings, in which:

Figure 1 shows a perspective view of the lower (wound contacting) surface of a wound dressing according to the invention; and

10

Figure 2 shows a partial transverse cross section (not to scale) through the island region of the dressing of Figure 1.

Referring to Figure 1, the wound dressing is an island-type self-adhesive
15 wound dressing comprising a backing layer 1 of microporous liquid-impermeable polyurethane foam, such as ESTANE 5714F (Registered Trade Mark). The backing layer is permeable to water vapor, but impermeable to wound exudate and microorganisms.

20 The backing layer 1 is coated with a substantially continuous layer 2 of pressure-sensitive polyurethane adhesive.

The absorbent layer 3 is a layer of hydrophilic polyurethane foam prepared as described in EP-A-0541391 and having a basis weight of about 350g/m² and a
25 thickness of about 1.5 mm.

The top sheet 4 extends over the absorbent layer 3 and is wrapped partially around the absorbent layer 3 and the edges 5 of the top sheet are adhered to the backing layer 1 behind the absorbent layer 3 by the adhesive 2. This can be seen
30 more clearly in Figure 2. The top sheet is a polyethylene film that has been perforated with about 90 perforations per cm², each perforation having a substantially conical shape as hereinbefore described, a maximum hole diameter of about 0.5 mm, an open area of 16% of the total area of the front face, a

thickness by weight of about 43 micrometers and an embossed thickness of about 0.5 mm. Such top sheets are available from Tredegar Film Products, Richmond, Virginia under the Registered Trade Mark VISPORE.

5 Referring to Figure 2, the top sheet 4 presents a smooth, perforated top surface to the wound. The back surface of the top sheet 4 is coated with a layer of hydrogel 6. The hydrogel 6 has a dry basis weight of 30g/m² and consists of bovine gelatin cross-linked with glutaraldehyde or formaldehyde.

10 The wound facing surface of the dressing shown in Figure 1 is protected by two silicone-coated release papers 8,9, packed in a microorganism-impermeable pouch, and sterilised using gamma radiation.

In use, the dressing is removed from the package, the release papers are
15 removed, and the dressing is adhered to the skin around the wound with the top sheet in contact with the wound to provide a sterile and absorbent dressing. The hydrogel and top sheet interact to provide a moist but not wet wound environment for a wide range of wounds over an extended period.

20 The above embodiment has been described by way of example only. Many other embodiments falling within the scope of the accompanying claims will be apparent to the skilled reader.

CLAIMS

1. A wound dressing comprising: a liquid-permeable top sheet having a wound facing surface and a back surface, said top sheet being adapted to block or restrict
5 passage of liquid from the back surface to the wound facing surface; and a hydrogel layer adjacent to the back surface of the top sheet.
2. A wound dressing according to claim 1, further comprising an absorbent layer adjacent to the back surface of the top sheet.
- 10 3. A wound dressing according to any preceding claim, wherein the absorbent layer comprises a layer of hydrophilic foam, a superabsorbent, or a combination thereof.
- 15 4. A wound dressing according to claim 2 or 3, wherein the absorbent layer further comprises a medicament.
5. A wound dressing according to any preceding claim, wherein the dressing further comprises a substantially liquid-impermeable backing layer over the
20 absorbent layer.
6. A wound dressing according to claim 5, further comprising a layer of adhesive on the surface of the backing layer facing the top sheet.
- 25 7. A wound dressing according to claim 6, wherein the backing layer extends beyond at least one edge of the absorbent layer to provide an adhesive-coated margin adjacent to said edge for adhering the dressing to a surface.
8. A wound dressing according to any preceding claim, wherein the top sheet
30 comprises a porous, substantially hydrophobic, non-woven fabric.
9. A wound dressing according to any preceding claim, wherein the top sheet is formed from a liquid-impermeable sheet material provided with tapered

capillaries, each capillary having a base substantially in the wound facing surface of the top sheet and an apical opening remote from the wound facing surface of the top sheet.

5 10. A wound dressing according to claim 9, wherein the capillaries are substantially in the form of truncated cones.

11. A wound dressing according to claim 9 or 10, wherein the capillaries have a base opening dimension as herein defined of from 0.15 mm to 6 mm, and an
10 apical opening dimension of from 0.1 to 2.5 mm.

12. A wound dressing according to claim 11, wherein the capillaries have a base opening dimension as herein defined of from 0.5 mm to 1.5 mm, and an apical opening dimension of from 0.1 to 0.5 mm.

15

13. A wound dressing according to any of claims 9 to 12, wherein the capillaries have an average angle of taper as herein defined of from 10 to 60 degrees.

14. A wound dressing according to any preceding claim, wherein the hydrogel
20 layer has a dry basis weight of from 10 to 200g/m².

15. A wound dressing according to any preceding claim, wherein the hydrogel layer comprises a hydrogel material selected from polyurethane gels, biopolymer gels, carboxymethyl cellulose gels, hydroxyethyl cellulose gels hydroxypropyl
25 methyl cellulose, modified acrylamides and mixtures thereof.

16. A wound dressing according to any preceding claim, wherein the hydrogel layer comprises a hydrogel material selected from gels formed from vinyl alcohols, vinyl esters, vinyl ethers and carboxy vinyl monomers, meth(acrylic) acid,
30 acrylamide, N-vinyl pyrrolidone, acylamidopropane sulphonic acid, pluronic (block polyethylene glycol, block polypropylene glycol)polystyrene maleic acid, NN-dimethylacrylamide, diacetone acrylamide or acryloyl morpholine.

17. A wound dressing according to any preceding claim, wherein the hydrogel layer comprises an emollient.

18. A wound dressing according to claim 17, wherein the emollient is selected
5 from the group consisting of white soft paraffin, yellow soft paraffin, liquid paraffin, urea creams, lanolin, sodium pyrrolidone carboxylate, evening primrose extract (gamma linolenic acid), soya oil, tea tree oil, coconut oil, almond oil, camomile extract, cod liver oil, peanut oil, emu oil, aloe vera, sunflower oil, avocado oil, jojoba oil, cocoamide, and mixtures thereof.

10

19. A wound dressing according to any preceding claim, wherein the hydrogel layer comprises an active therapeutic agent or an antimicrobial agent.

20. A wound dressing according to claim 19, wherein the hydrogel layer
15 comprises a silver compound.

21. A wound dressing according to any preceding claim, wherein the hydrogel layer is apertured in register with apertures in the top sheet.

20 22. A wound dressing according to any preceding claim, further comprising one or more protective cover sheets over the wound facing surface of the top sheet.

23. A wound dressing according to any preceding claim, wherein the dressing is sterile and packaged in a microorganism-impermeable container.

25

24. Use of a wound dressing according to any preceding claim for the preparation of a dressing for application to a wound.

1/1

FIG. 1

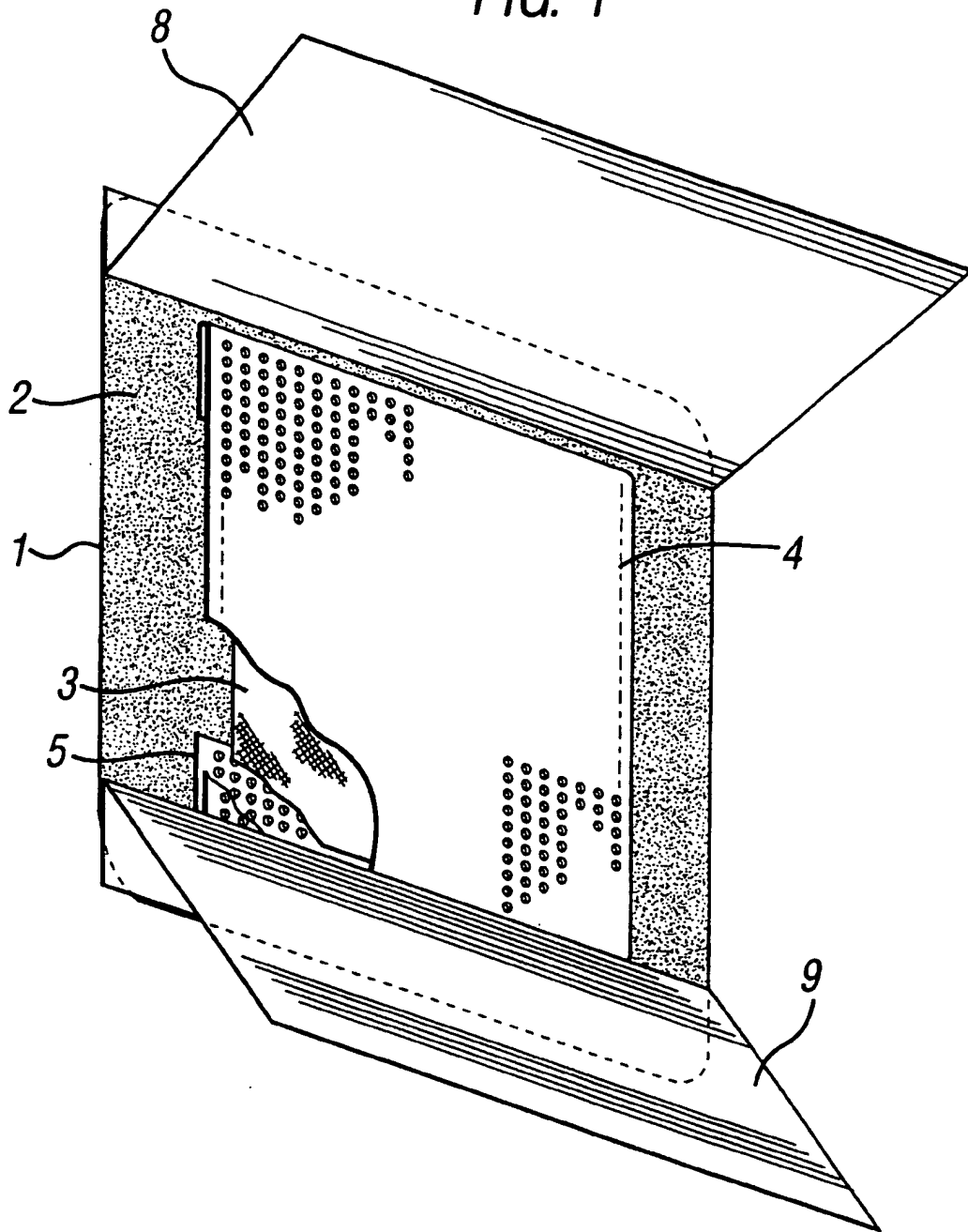
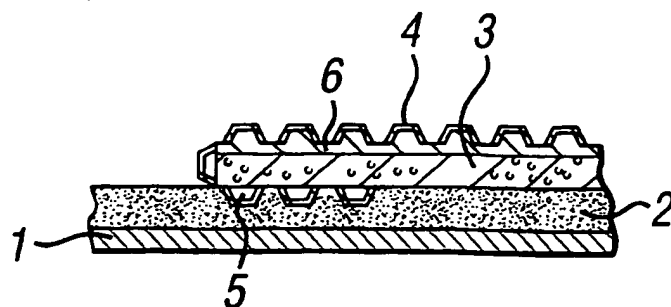

FIG. 2



INTERNATIONAL SEARCH REPORT

Internu application No
PCT/00 02/05253

A. CLASSIFICATION OF SUBJECT MATTER
IPC 7 A61F13/02

According to International Patent Classification (IPC) or to both national classification and IPC

B. FIELDS SEARCHED
Minimum documentation searched (classification system followed by classification symbols)
IPC 7 A61F

Documentation searched other than minimum documentation to the extent that such documents are included in the fields searched

Electronic data base consulted during the international search (name of data base and, where practical, search terms used)
EPO-Internal, WPI Data

C. DOCUMENTS CONSIDERED TO BE RELEVANT

Category *	Citation of document, with indication, where appropriate, of the relevant passages	Relevant to claim No.
P, X	WO 02 38097 A (JOHNSON & JOHNSON MEDICAL LTD ;ADDISON DEBORAH (GB); SILCOCK DEREK) 16 May 2002 (2002-05-16) abstract figures 1,2 claims 1-24 -----	1-24

Further documents are listed in the continuation of box C. Patent family members are listed in annex.

* Special categories of cited documents :

A document defining the general state of the art which is not considered to be of particular relevance

E earlier document but published on or after the international filing date

L document which may throw doubts on priority claim(s) or which is cited to establish the publication date of another citation or other special reason (as specified)

O document referring to an oral disclosure, use, exhibition or other means

P document published prior to the international filing date but later than the priority date claimed

T later document published after the international filing date or priority date and not in conflict with the application but cited to understand the principle or theory underlying the invention

X document of particular relevance; the claimed invention cannot be considered novel or cannot be considered to involve an inventive step when the document is taken alone

Y document of particular relevance; the claimed invention cannot be considered to involve an inventive step when the document is combined with one or more other such documents, such combination being obvious to a person skilled in the art.

8 document member of the same patent family

Date of the actual completion of the international search 12 March 2003	Date of mailing of the international search report 21/03/2003
Name and mailing address of the ISA European Patent Office, P.B. 5818 Patentlaan 2 NL - 2280 HV Rijswijk Tel. (+31-70) 340-2040, Tx. 31 651 epo nl, Fax: (+31-70) 340-3016	Authorized officer Bourout, G

INTERNATIONAL SEARCH REPORT

International Application No

PCT/JP 02/05253

Patent document cited in search report	Publication date	Patent family member(s)	Publication date
WO 0238097 A	16-05-2002	AU 1255202 A WO 0238097 A1	21-05-2002 16-05-2002
